

TOPIC: 193006
KNOWLEDGE: K1.04 [3.4/3.6]
QID: P78

The possibility of water hammer in a liquid system is minimized by...

- A. maintaining temperature above the saturation temperature.
 - B. starting centrifugal pumps with the casing vent valve fully open.
 - C. starting positive displacement pumps with the discharge valve closed.
 - D. venting systems prior to starting centrifugal pumps.
- ██████████

TOPIC: 193006
KNOWLEDGE: K1.04 [3.4/3.6]
QID: P278

Which one of the following methods will increase the possibility and/or severity of water hammer?

- A. Opening and closing system valves slowly.
 - B. Venting fluid systems prior to starting a pump.
 - C. Starting a centrifugal pump with the discharge valve fully open.
 - D. Starting a centrifugal pump with the discharge valve fully closed.
- ██████████

TOPIC: 193006
KNOWLEDGE: K1.04 [3.4/3.6]
QID: P679 (B279)

A sudden stop of fluid flow in a piping system, due to rapid closure of an isolation valve, will most likely result in...

- A. check valve slamming.
- B. pump runout.
- C. water hammer.
- D. pressurized thermal shock.



TOPIC: 193006
KNOWLEDGE: K1.04 [3.4/3.6]
QID: P879

One reason for keeping condensate out of the steam lines is to...

- A. minimize corrosion buildup.
- B. reduce heat losses.
- C. eliminate steam traps.
- D. prevent water/steam hammer.



TOPIC: 193006
KNOWLEDGE: K1.04 [3.4/3.6]
QID: P1079

The possibility of water hammer will be increased by...

- A. maintaining the discharge line filled with liquid on an automatically starting pump.
- B. condensation in a steam line just prior to initiating flow.
- C. warming steam lines prior to initiating steam flow.
- D. slowly closing the discharge valve on an operating pump.



TOPIC: 193006
KNOWLEDGE: K1.04 [3.4/3.6]
QID: P1279

To minimize the possibility of water hammer when initiating flow in a system, the operator should...

- A. vent the system prior to initiating flow.
- B. vent the system only after flow has been initiated.
- C. fully open the pump discharge valve prior to starting a pump.
- D. rapidly open the pump discharge valve after a pump is running.



TOPIC: 193006
KNOWLEDGE: K1.04 [3.4/3.6]
QID: P1879 (B2779)

Which one of the following describes why large steam lines are gradually warmed instead of suddenly admitting full steam flow?

- A. To minimize the possibility of stress corrosion cracking of the steam lines.
 - B. To minimize the total thermal expansion of the steam lines.
 - C. To minimize the potential for water hammer in the steam lines.
 - D. To minimize the heat loss from the steam lines.
- ██████████

TOPIC: 193006
KNOWLEDGE: K1.04 [3.4/3.6]
QID: P2079 (B2081)

Which one of the following will minimize the possibility of water hammer?

- A. Draining the discharge line of a centrifugal pump after shutdown.
 - B. Draining condensate out of steam lines before and after initiating flow.
 - C. Starting a centrifugal pump with its discharge valve fully open.
 - D. Starting a positive displacement pump with its discharge valve partially closed.
- ██████████

TOPIC: 193006
KNOWLEDGE: K1.04 [3.4/3.6]
QID: P2279 (B2679)

Which one of the following operating practices minimizes the possibility of water hammer?

- A. Change valve positions as rapidly as possible.
- B. Start centrifugal pumps with the discharge valve throttled.
- C. Start positive displacement pumps with the discharge valve closed.
- D. Vent systems only after initiating system flow.



TOPIC: 193006
KNOWLEDGE: K1.04 [3.4/3.6]
QID: P4042 (B4041)

Refer to the drawing of two lengths of 6-inch diameter pipe, each containing an identical automatic isolation valve. The actual pipe lengths are proportional to their symbols in the drawing

Water at 65°F is flowing at 1,000 gpm through each pipe. If the isolation valves instantly close, valve A piping will experience a pressure increase that is _____ the pressure increase experienced by valve B piping; and the pressure spike will dissipate quicker in the _____ length of pipe.

- A. equal to; shorter
- B. equal to; longer
- C. less than; shorter
- D. less than; longer

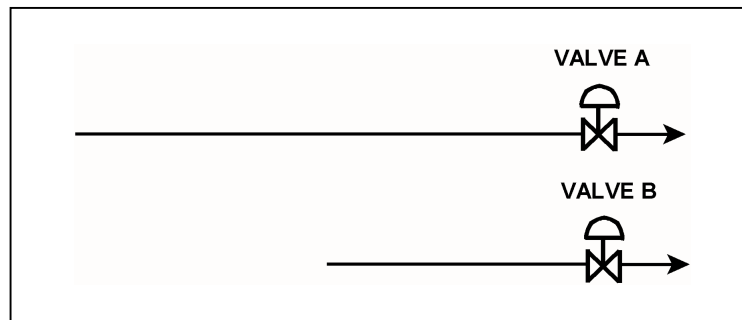

TOPIC: 193006
KNOWLEDGE: K1.04 [3.4/3.6]
QID: P6242 (B6241)

Refer to the drawing of two lengths of 16-inch diameter pipe, each containing an identical automatic isolation valve. The actual pipe lengths are proportional to their symbols in the drawing.

Water is flowing at 10,000 gpm through each pipe when both isolation valves instantly close.
Consider two cases:

Case 1: The water temperature upstream of both valves is 65°F.

Case 2: The water temperature is 65°F upstream of valve A, and 85°F upstream of valve B.

For which case(s), if any, will valve A experience a pressure spike that is greater than the pressure spike at valve B?

- A. Case 1 only
- B. Case 2 only
- C. Both cases
- D. Neither case

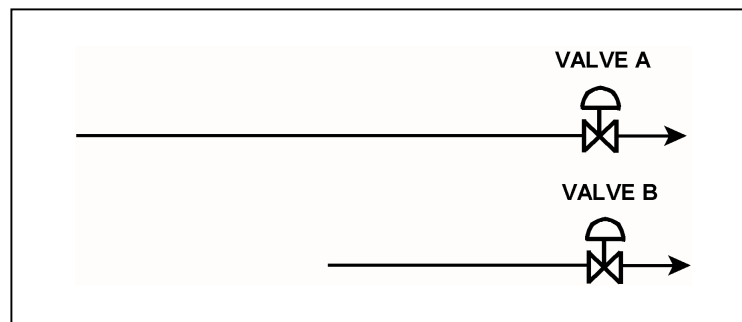

TOPIC: 193006
KNOWLEDGE: K1.04 [3.4/3.6]
QID: P6742 (B6741)

Refer to the drawing of two lengths of 16-inch diameter pipe, each containing an identical automatic isolation valve. The actual pipe lengths are proportional to their symbols in the drawing.

Water is flowing at 10,000 gpm through each pipe when both isolation valves instantly close.

Consider two cases:

Case 1: The water temperature upstream of both valves is 65°F.

Case 2: The water temperature is 85°F upstream of valve A, and 65°F upstream of valve B.

For which case(s), if any, will valve A experience a pressure spike that is greater than the pressure spike at valve B?

- A. Case 1 only
- B. Case 2 only
- C. Both cases
- D. Neither case

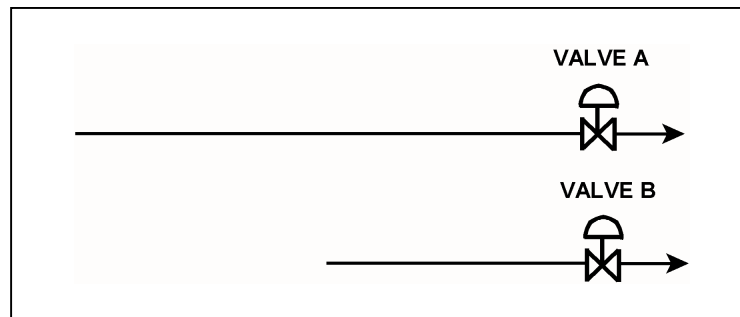

TOPIC: 193006
KNOWLEDGE: K1.04 [3.4/3.6]
QID: P7620 (B7620)

Which one of the following will result in a higher probability and/or severity of water hammer in a flowing water system?

- A. Gradual pipe bends rather than sharp pipe bends.
 - B. Shorter pipe lengths rather than longer pipe lengths.
 - C. Lower initial flow rates rather than higher initial flow rates.
 - D. Shorter valve stroke times rather than longer valve stroke times.
- 

TOPIC: 193006
KNOWLEDGE: K1.05 [2.9/3.0]
QID: P380 (B383)

An 85 gpm leak to atmosphere has developed from a cooling water system that is operating at 100 psig. Which one of the following will be the approximate leak rate when system pressure has decreased to 50 psig?

- A. 33 gpm
 - B. 41 gpm
 - C. 52 gpm
 - D. 60 gpm
- 

TOPIC: 193006
KNOWLEDGE: K1.05 [2.9/3.0]
QID: P579

Mass flow rate equals volumetric flow rate times...

- A. specific volume.
- B. density.
- C. specific gravity.
- D. velocity.



TOPIC: 193006
KNOWLEDGE: K1.05 [2.9/3.0]
QID: P680 (B681)

A 55 gpm leak to atmosphere has developed from a cooling water system that is operating at 100 psig. Which one of the following will be the approximate leak rate when system pressure has decreased to 50 psig?

- A. 28 gpm
- B. 32 gpm
- C. 39 gpm
- D. 45 gpm



TOPIC: 193006
KNOWLEDGE: K1.05 [2.9/3.0]
QID: P1382

A 75 gpm leak to atmosphere has developed from a cooling water system that is operating at 80 psig. Which one of the following will be the approximate leak rate when system pressure has decreased to 40 psig?

- A. 38 gpm
- B. 44 gpm
- C. 53 gpm
- D. 59 gpm



TOPIC: 193006
KNOWLEDGE: K1.05 [2.9/3.0]
QID: P1580 (B1979)

A 60 gpm leak to atmosphere has developed from a cooling water system that is operating at 150 psig. Which one of the following will be the approximate leak rate when system pressure has decreased to 75 psig?

- A. 15 gpm
- B. 30 gpm
- C. 42 gpm
- D. 53 gpm



TOPIC: 193006
KNOWLEDGE: K1.05 [2.9/3.0]
QID: P1679 (B2981)

A 100 gpm leak to atmosphere has developed from a cooling water system that is operating at 60 psig. Which one of the following will be the approximate leak rate when system pressure has decreased to 20 psig?

- A. 33 gpm
- B. 53 gpm
- C. 58 gpm
- D. 71 gpm



TOPIC: 193006
KNOWLEDGE: K1.05 [2.9/3.0]
QID: P1779 (B1783)

A 100 gpm leak to atmosphere has developed from a cooling water system that is operating at 45 psig. Which one of the following will be the approximate leak rate when system pressure has decreased to 30 psig?

- A. 25 gpm
- B. 50 gpm
- C. 67 gpm
- D. 82 gpm



TOPIC: 193006
KNOWLEDGE: K1.05 [2.9/3.0]
QID: P1986

A 47 gpm leak to atmosphere has developed from a cooling water system that is operating at 150 psig. Which one of the following will be the approximate leak rate when system pressure has decreased to 75 psig?

- A. 24 gpm
- B. 33 gpm
- C. 39 gpm
- D. 46 gpm



TOPIC: 193006
KNOWLEDGE: K1.05 [2.9/3.0]
QID: P2080 (B2080)

An 80 gpm leak to atmosphere has developed from a cooling water system that is operating at 100 psig. Which one of the following will be the approximate leak rate when system pressure has decreased to 75 psig?

- A. 69 gpm
- B. 60 gpm
- C. 51 gpm
- D. 40 gpm



TOPIC: 193006
KNOWLEDGE: K1.05 [2.9/3.0]
QID: P2379 (B2381)

A 60 gpm leak to atmosphere has developed from a cooling water system that is operating at 150 psig. Which one of the following will be the approximate leak rate when system pressure has decreased to 100 psig?

- A. 27 gpm
- B. 35 gpm
- C. 40 gpm
- D. 49 gpm



TOPIC: 193006
KNOWLEDGE: K1.05 [2.9/3.0]
QID: P2779 (B2781)

An 80 gpm leak to atmosphere has developed from a cooling water system that is operating at 150 psig. Which one of the following will be the approximate leak rate when system pressure has decreased to 75 psig?

- A. 20 gpm
- B. 40 gpm
- C. 49 gpm
- D. 57 gpm



TOPIC: 193006
KNOWLEDGE: K1.05 [2.9/3.0]
QID: P2980

An 80 gpm leak to atmosphere has developed from a cooling water system that is operating at 150 psig. Which one of the following will be the approximate leak rate when system pressure has decreased to 100 psig?

- A. 36 gpm
- B. 53 gpm
- C. 56 gpm
- D. 65 gpm



TOPIC: 193006
KNOWLEDGE: K1.05 [2.9/3.0]
QID: P3080 (B3181)

A 75 gpm leak to atmosphere has developed from a cooling water system that is operating at 100 psig. Which one of the following will be the approximate leak rate when system pressure has decreased to 80 psig?

- A. 26 gpm
- B. 39 gpm
- C. 56 gpm
- D. 67 gpm



TOPIC: 193006
KNOWLEDGE: K1.05 [2.9/3.0]
QID: P3780

Which one of the following describes the relationship between the main steam mass flow rate leaving a steam generator and the main feedwater mass flow rate entering the same steam generator at steady-state power operation? (Assume no other addition/removal of steam generator inventory.)

- A. The mass flow rates will be the same only if downcomer level is constant.
- B. The mass flow rates will be the same only if the reactor is operating near rated power.
- C. The main steam mass flow rate is smaller than the main feedwater mass flow rate by the amount of moisture removed by the steam generator moisture separators.
- D. The main steam mass flow rate is greater than the main feedwater mass flow rate by the amount of moisture removed by the steam generator moisture separators.



TOPIC: 193006
KNOWLEDGE: K1.05 [2.9/3.0]
QID: P5342 (B5342)

A heat exchanger has the following initial cooling water inlet temperature and differential pressure (ΔP) parameters:

Inlet Temperature = 70°F
Heat Exchanger ΔP = 10 psi

Six hours later, the current heat exchanger cooling water parameters are:

Inlet Temperature = 85°F
Heat Exchanger ΔP = 10 psi

In comparison to the initial cooling water mass flow rate, the current mass flow rate is...

- A. lower, because the density of the cooling water has decreased.
- B. higher, because the velocity of the cooling water has increased.
- C. the same, because the changes in cooling water velocity and density offset.
- D. the same, because the heat exchanger cooling water ΔP is the same.



TOPIC: 193006
KNOWLEDGE: K1.05 [2.9/3.0]
QID: P7342 (B7342)

An 80 gpm leak to atmosphere has developed from a cooling water system that is operating at 150 psig. Which one of the following will be the approximate leak rate when system pressure has decreased to 100 psig?

- A. 70 gpm
- B. 65 gpm
- C. 53 gpm
- D. 47 gpm



TOPIC: 193006
KNOWLEDGE: K1.06 [2.8/2.9]
QID: P580

Reactor coolant system (RCS) hot leg temperature is constant at 568°F while RCS pressure is decreasing due to a small reactor coolant leak. Which one of the following RCS pressure ranges includes the pressure at which two-phase flow will first occur in the hot leg?

- A. 1,250 to 1,201 psig
 - B. 1,200 to 1,151 psig
 - C. 1,150 to 1,101 psig
 - D. 1,100 to 1,051 psig
- 

TOPIC: 193006
KNOWLEDGE: K1.06 [2.8/2.9]
QID: P1180

Reactor coolant system (RCS) hot leg temperature is constant at 538°F while RCS pressure is decreasing due to a small reactor coolant leak. Which one of the following RCS pressure ranges includes the pressure at which two-phase flow will first occur in the hot leg?

- A. 1,100 to 1,151 psig
 - B. 1,050 to 1,001 psig
 - C. 1,000 to 951 psig
 - D. 950 to 901 psig
- 

TOPIC: 193006
KNOWLEDGE: K1.06 [2.8/2.9]
QID: P1480

Reactor coolant system (RCS) hot leg temperature is constant at 520°F while RCS pressure is decreasing due to a small reactor coolant leak. Which one of the following pressure ranges includes the pressure at which two-phase flow will first occur in the hot leg?

- A. 950 to 901 psig
 - B. 900 to 851 psig
 - C. 850 to 801 psig
 - D. 800 to 751 psig
- 

TOPIC: 193006
KNOWLEDGE: K1.06 [2.8/2.9]
QID: P2581

Reactor coolant system (RCS) hot leg temperature is constant at 552°F while RCS pressure is decreasing due to a small reactor coolant leak. Which one of the following pressure ranges includes the pressure at which two-phase flow will first occur in the hot leg?

- A. 1,100 to 1,051 psig
 - B. 1,050 to 1,001 psig
 - C. 1,000 to 951 psig
 - D. 950 to 901 psig
- 

TOPIC: 193006
KNOWLEDGE: K1.06 [2.8/2.9]
QID: P7649 (B7649)

If the quality of a flowing steam-water mixture is known, what additional information, if any, is needed to determine the percent moisture content of the steam-water mixture?

- A. The mass flow rate of the mixture.
- B. The specific volume of the mixture.
- C. The pressure and/or temperature of the mixture.
- D. No additional information is needed.



TOPIC: 193006
KNOWLEDGE: K1.06 [2.8/2.9]
QID: P7689

A nuclear power plant is initially operating at steady-state 100 percent power. If an unplanned load rejection causes the main generator load to rapidly decrease to 90 percent, the voids in the two-phase flow in the steam generator tube bundle region will initially _____; which causes indicated steam generator water level (measured in the downcomer) to initially _____.

- A. shrink; decrease
- B. shrink; increase
- C. expand; decrease
- D. expand; increase



TOPIC: 193006
KNOWLEDGE: K1.07 [2.7/2.7]
QID: P581

A nuclear power plant is recovering from a loss of offsite power that caused all reactor coolant pumps (RCPs) to stop. Pressurizer level indication is off-scale high.

Which one of the following is most likely to occur if the steam generator (SG) temperatures are 50°F higher than their associated reactor coolant system (RCS) loop temperatures when an RCP is restarted?

- A. Localized water hammer in the RCS.
- B. Pressurized thermal shock to the SGs.
- C. A large pressure spike throughout the RCS.
- D. Inadvertent lifting of a SG atmospheric relief valve.



TOPIC: 193006
KNOWLEDGE: K1.08 [2.8/1.8]
QID: P279 (B143)

A centrifugal water pump was returned to service after maintenance. However, the operator failed to vent the pump.

Compared to normal pump operating conditions, after the pump is started the operator will see a _____ flow rate and a _____ discharge head.

- A. higher; lower
- B. higher; higher
- C. lower; lower
- D. lower; higher



TOPIC: 193006
KNOWLEDGE: K1.08 [2.8/2.8]
QID: P3481

Refer to the drawing of a cooling water system (see figure below).

Centrifugal pump A is circulating water at 100°F. Which one of the following will cause the centrifugal pump to operate closer to a condition in which gas/vapor binding can occur?

- A. Surge tank level is raised by 5 percent.
- B. Service water flow rate is decreased by 5 percent.
- C. The pump discharge valve is repositioned to decrease cooling water system flow rate by 5 percent.
- D. Makeup water containing a high concentration of total dissolved solids is added to the cooling water system.

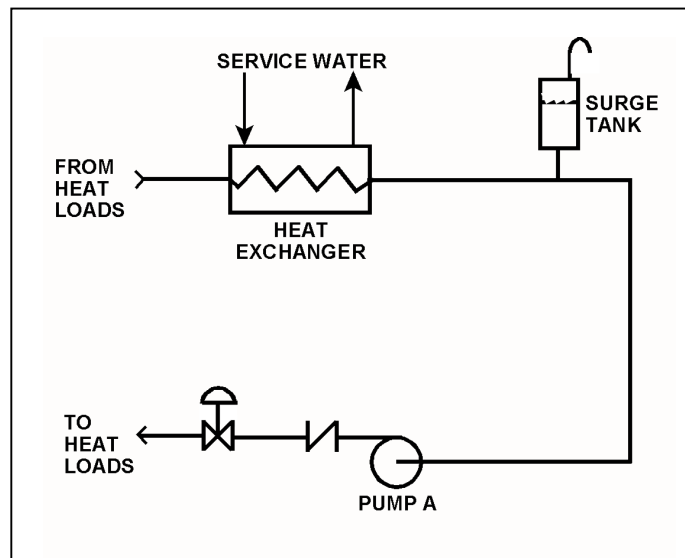

TOPIC: 193006
KNOWLEDGE: K1.10 [3.3/3.4]
QID: P80 (B79)

If a valve closure suddenly stops fluid flow, the resulting piping system pressure transient is referred to as...

- A. cavitation.
- B. shutoff head.
- C. water hammer.
- D. valve chatter.



TOPIC: 193006
KNOWLEDGE: K1.10 [3.3/3.4]
QID: P381 (B380)

The major concern with starting a main feedwater pump with downstream fluid in a saturated condition is...

- A. cavitation.
- B. water hammer.
- C. thermal shock.
- D. positive reactivity addition.



TOPIC: 193006
KNOWLEDGE: K1.10 [3.3/3.4]
QID: P2480 (B1180)

Which one of the following will increase the possibility of water hammer?

- A. Opening and closing system valves very slowly.
- B. Venting liquid systems only after initiating system flow.
- C. Starting centrifugal pumps with the discharge valve closed.
- D. Starting positive displacement pumps with the discharge valve open.



TOPIC: 193006
KNOWLEDGE: K1.10 [3.3/3.4]
QID: P2880

The primary reason for slowly opening the discharge valve of a large motor-driven centrifugal cooling water pump after starting the pump is to minimize the...

- A. net positive suction head requirements.
- B. potential for a water hammer.
- C. motor running current requirements.
- D. potential for pump cavitation.



TOPIC: 193006
KNOWLEDGE: K1.11 [3.1/3.3]
QID: P79

Cavitation in an operating pump can be caused by...

- A. lowering the pump suction temperature.
- B. throttling the pump suction valve.
- C. increasing the pump backpressure.
- D. increasing the pump suction pressure.



TOPIC: 193006
KNOWLEDGE: K1.11 [3.1/3.3]
QID: P149

Cavitation of a centrifugal pump in an open system is indicated by _____ discharge pressure and _____ flow rate.

- A. low; low
- B. high; high
- C. low; high
- D. high; low



TOPIC: 193006
KNOWLEDGE: K1.11 [3.1/3.3]
QID: P382 (B80)

Which one of the following is most likely to cause cavitation in an operating centrifugal pump?

- A. Lowering the suction temperature.
 - B. Throttling the pump suction valve.
 - C. Throttling the pump discharge valve.
 - D. Decreasing the pump speed.
- ██████████

TOPIC: 193006
KNOWLEDGE: K1.11 [3.1/3.3]
QID: P481

While on surveillance rounds, an operator notices that a centrifugal pump is making a great deal of noise (like marbles rattling inside the pump casing) and the pump discharge pressure is fluctuating.

This set of conditions indicates that the pump is experiencing...

- A. runout.
 - B. cavitation.
 - C. bearing deterioration.
 - D. packing deterioration.
- ██████████

TOPIC: 193006
KNOWLEDGE: K1.11 [3.1/3.3]
QID: P1181

Indications of pump cavitation include abnormally _____ pump discharge pressure and abnormally _____ pump flow rate.

- A. low; low
 - B. low; high
 - C. high; low
 - D. high; high
- 

TOPIC: 193006
KNOWLEDGE: K1.11 [3.1/3.3]
QID: P1381

Cavitation is the formation of vapor bubbles in the _____ of a pump with the subsequent collapse of these bubbles in the pump _____.

- A. impeller; casing
 - B. impeller; discharge piping
 - C. volute; casing
 - D. volute; discharge piping
- 

TOPIC: 193006
KNOWLEDGE: K1.11 [3.1/3.3]
QID: P2680 (B280)

Cavitation is the formation of vapor bubbles in the _____ pressure area of a pump followed by the _____ of these bubbles within the pump casing.

- A. low; expansion
 - B. low; collapse
 - C. high; expansion
 - D. high; collapse
- 

TOPIC: 193006
KNOWLEDGE: K1.11 [3.1/3.3]
QID: P2981 (B1880)

Pump cavitation occurs when vapor bubbles are formed at the eye of a pump impeller...

- A. because the localized flow velocity exceeds sonic velocity for the existing fluid temperature.
 - B. because the localized pressure exceeds the vapor pressure for the existing fluid temperature.
 - C. and enter a high pressure region of the pump where they collapse causing damaging pressure pulsations.
 - D. and are discharged from the pump where they expand into larger bubbles causing damaging pressure pulsations.
- 

TOPIC: 193006
KNOWLEDGE: K1.12 [2.5/2.6]
QID: P81

In an operating cooling water system with a constant water velocity, if water temperature decreases, system volumetric flow rate (gpm) will...

- A. remain the same, because the density of the water has not changed.
 - B. increase, because the density of the water has increased.
 - C. remain the same, because the water velocity has not changed.
 - D. increase, because the viscosity of the water has increased.
- ██████████

TOPIC: 193006
KNOWLEDGE: K1.12 [2.5/2.6]
QID: P281

Flow instruments that measure the mass flow rate of steam often have a density compensation feature because, for a steam pressure increase at a constant volumetric flow rate, steam density will _____ and the actual mass flow rate will _____.

- A. decrease; increase
 - B. increase; decrease
 - C. increase; increase
 - D. decrease; decrease
- ██████████

TOPIC: 193006
KNOWLEDGE: K1.12 [2.5/2.6]
QID: P982

A density-compensated flow instrument is being used to measure mass flow rate in a steam system. If the pressure of the steam decreases, indicated mass flow rate will: (Assume volumetric flow rate is constant.)

- A. increase for all steam conditions.
- B. decrease for all steam conditions.
- C. increase, but only if the steam is saturated (not superheated).
- D. decrease, but only if the steam is saturated (not superheated).



TOPIC: 193006
KNOWLEDGE: K1.12 [2.5/2.6]
QID: P1083

A steam generator transient causes main steam pressure to decrease although the actual steam mass flow rate to the main turbine remains constant. If the main steam flow instrument is not density compensated, indicated steam mass flow rate will...

- A. increase, due to the increased velocity of the steam.
- B. increase, due to the increased density of the steam.
- C. decrease, due to the decreased velocity of the steam.
- D. decrease, due to the decreased density of the steam.



TOPIC: 193006
KNOWLEDGE: K1.12 [2.5/2.6]
QID: P1182

A cooling water system is supplying 1.0×10^6 lbm/hour of flow at 100°F . Assuming volumetric flow rate does not change, which one of the following will be the mass flow rate in the system if cooling water temperature increases to 140°F ?

- A. 7.5×10^5 lbm/hr
 - B. 8.3×10^5 lbm/hr
 - C. 9.0×10^5 lbm/hr
 - D. 9.9×10^5 lbm/hr
- 

TOPIC: 193006
KNOWLEDGE: K1.12 [2.5/2.6]
QID: P1780

A reactor coolant system is supplying 1.0×10^8 lbm/hour of coolant flow at a temperature of 100°F . Assuming volumetric flow rate does not change, which one of the following is the approximate mass flow rate that will be supplied by the system if cooling water temperature increases to 400°F ?

- A. 1.2×10^8 lbm/hr
 - B. 1.1×10^8 lbm/hr
 - C. 9.2×10^7 lbm/hr
 - D. 8.7×10^7 lbm/hr
- 

TOPIC: 193006
KNOWLEDGE: K1.12 [2.5/2.6]
QID: P2182

A reactor coolant system is supplying 1.0×10^8 lbm/hr of coolant flow at a temperature of 100°F. Assuming volumetric flow rate does not change, which one of the following is the approximate mass flow rate that will be supplied by the system if coolant temperature increases to 500°F?

- A. 1.2×10^8 lbm/hr
 - B. 1.1×10^8 lbm/hr
 - C. 8.7×10^7 lbm/hr
 - D. 7.9×10^7 lbm/hr
- 

TOPIC: 193006
KNOWLEDGE: K1.12 [2.5/2.6]
QID: P2681

A cooling water system is supplying 2,000 lbm/min coolant flow at a temperature of 100°F. Assuming volumetric flow rate does not change, which one of the following is the approximate mass flow rate that will be supplied by the system if cooling water temperature increases to 140°F?

- A. 1,964 lbm/min
 - B. 1,980 lbm/min
 - C. 2,020 lbm/min
 - D. 2,036 lbm/min
- 

TOPIC: 193006
KNOWLEDGE: K1.12 [2.5/2.6]
QID: P2882

A steam generator transient causes main steam pressure to increase although the actual mass flow rate of steam remains constant. If the main steam flow instrument is not density compensated, the increased main steam pressure will cause indicated steam mass flow rate to...

- A. increase, due to a higher steam velocity.
 - B. increase, due to a greater steam density.
 - C. decrease, due to a lower steam velocity.
 - D. decrease, due to a reduced steam density.
- 

TOPIC: 193006
KNOWLEDGE: K1.12 [2.5/2.6]
QID: P3081 (B3032)

The volumetric flow rate of cooling water entering a heat exchanger is 500 gpm.

Given the following:

- Cooling water pressure entering and leaving the heat exchanger is 10 psig.
- Cooling water inlet temperature is 90°F.
- Cooling water outlet temperature is 160°F.
- Heat exchanger inlet and outlet piping have the same diameter.

What is the approximate volumetric flow rate of the cooling water exiting the heat exchanger?

- A. 496 gpm
 - B. 500 gpm
 - C. 504 gpm
 - D. 509 gpm
- 

TOPIC: 193006
KNOWLEDGE: K1.12 [2.5/2.6]
QID: P3783 (B3733)

A condensate pump is taking suction on a main condenser hotwell, containing water at 100°F, and discharging the water at a volumetric flow rate of 100,000 gpm to the main feedwater system. The main feedwater system heats the water to 400°F before it enters the steam generators. Assume there is no leakage, and no bypass or recirculation flow paths are in use.

What is the approximate volumetric flow rate of the feedwater entering the steam generators?

- A. 100,000 gpm
 - B. 105,000 gpm
 - C. 109,000 gpm
 - D. 115,000 gpm
- 

TOPIC: 193006
KNOWLEDGE: K1.15 [3.1/3.3]
QID: P147

Operating two pumps in parallel instead of operating a single pump will result in a...

- A. large increase in pump head and a small increase in pump flow rate.
 - B. small increase in pump head and a small increase in pump flow rate.
 - C. small increase in pump head and a large increase in pump flow rate.
 - D. large increase in pump head and a large increase in pump flow rate.
- 

TOPIC: 193006
KNOWLEDGE: K1.15 [3.1/3.3]
QID: P280

The major effect of starting a second centrifugal pump in parallel with an operating centrifugal pump in an open system is increased...

- A. system pressure.
 - B. system flow rate.
 - C. pump discharge pressure.
 - D. pump flow rate.
- 

TOPIC: 193006
KNOWLEDGE: K1.15 [3.1/3.3]
QID: P282

To decrease the flow rate through an operating positive displacement pump, an operator should...

- A. throttle the pump discharge valve partially closed.
 - B. throttle the pump suction valve partially closed.
 - C. decrease the pump's available net positive suction head.
 - D. decrease the pump's speed.
- 

TOPIC: 193006
KNOWLEDGE: K1.15 [3.1/3.3]
QID: P981

Which one of the following will decrease the head loss occurring in an operating cooling water system?

- A. Starting a second pump in parallel with the operating pump.
- B. Shifting two heat exchangers from parallel to series operation.
- C. Replacing a 10 foot section of 10-inch diameter pipe with a 20 foot section of 10-inch diameter pipe.
- D. Replacing a 20 foot section of 10-inch diameter pipe with a 20 foot section of 12-inch diameter pipe.



TOPIC: 193006
KNOWLEDGE: K1.15 [3.1/3.3]
QID: P1282

Two centrifugal pumps and two positive displacement pumps are able to be cross-connected to provide makeup water flow to a system. Each pump will produce 100 gpm at a system pressure of 1,000 psig.

If system pressure is 1,200 psig, which one of the following combinations will produce the greatest flow rate to the system?

- A. Two positive displacement pumps in series
- B. Two positive displacement pumps in parallel
- C. Two centrifugal pumps in series
- D. Two centrifugal pumps in parallel



TOPIC: 193006
KNOWLEDGE: K1.15 [3.1/3.3]
QID: P1683

Two centrifugal pumps and two positive displacement pumps are able to be cross-connected to provide makeup water flow to a system. Each pump will produce 100 gpm at a system pressure of 1,000 psig backpressure.

If system pressure is 800 psig, which one of the following combinations will produce the greatest flow rate to the system?

- A. Two centrifugal pumps in parallel.
- B. Two centrifugal pumps in series.
- C. Two positive displacement pumps in parallel.
- D. Two positive displacement pumps in series.



TOPIC: 193006
KNOWLEDGE: K1.15 [3.1/3.3]
QID: P1784 (B1725)

Two identical centrifugal pumps (CPs) and two identical positive displacement pumps (PDPs) are able to take suction on a vented water storage tank and provide makeup water flow to a cooling water system. The pumps are capable of being cross-connected to provide multiple configurations. In single pump alignment, each pump will supply 100 gpm at a system pressure of 1,000 psig.

Given the following information:

Centrifugal Pumps

Shutoff head = 1,500 psig
Maximum design pressure = 2,000 psig
Flow rate with no backpressure = 180 gpm

Positive Displacement Pumps

Maximum design pressure = 2,000 psig

Which one of the following pump configurations will supply the lowest makeup water flow rate to the system if system pressure is 1,700 psig?

- A. Two CPs in series
- B. Two CPs in parallel
- C. One PDP and one CP in series (CP supplying PDP)
- D. One PDP and one CP in parallel



TOPIC: 193006
KNOWLEDGE: K1.15 [3.1/3.3]
QID: P1979

Two identical centrifugal pumps (CPs) and two identical positive displacement pumps (PDPs) are able to take suction on a vented water storage tank and provide makeup water flow to a cooling water system. The pumps are capable of being cross-connected to provide multiple configurations. In single pump alignment, each pump will supply 100 gpm at a system pressure of 1,000 psig.

Given the following information:

Centrifugal Pumps

Shutoff head = 1,500 psig
Maximum design pressure = 2,000 psig
Flow rate with no backpressure = 180 gpm

Positive Displacement Pumps

Maximum design pressure = 2,000 psig

Which one of the following pump configurations will supply the highest makeup flow rate to the system if system pressure is 800 psig?

- A. One PDP and one CP in series (CP supplying PDP)
- B. One PDP and one CP in parallel
- C. Two CPs in series
- D. Two CPs in parallel



TOPIC: 193006
KNOWLEDGE: K1.15 [3.1/3.3]
QID: P2282 (B2281)

Water at 90°F and 50 psig is flowing through a 10-inch diameter pipe at 100 lbm/sec. The pipe then splits into two pipes, a 4-inch diameter pipe and an 8-inch diameter pipe.

Disregarding any flow restrictions other than pipe size, which one of the following lists the approximate flow rates through the 4-inch and 8-inch diameter pipes? (Assume that water velocity is the same in each pipe.)

	4-inch Pipe <u>(lbm/sec)</u>	8-inch Pipe <u>(lbm/sec)</u>
A.	20	80
B.	25	75
C.	30	70
D.	33	67



TOPIC: 193006
KNOWLEDGE: K1.15 [3.1/3.3]
QID: P2383 (B2324)

Two identical centrifugal pumps (CPs) and two identical positive displacement pumps (PDPs) are able to take suction on a vented water storage tank and provide makeup water flow to a cooling water system. The pumps are capable of being cross-connected to provide multiple configurations. In single pump alignment, each pump will supply 100 gpm at a system pressure of 1,200 psig.

Given the following information:

Centrifugal Pumps

Shutoff head = 1,500 psig
Maximum design pressure = 2,000 psig
Flow rate with no backpressure = 180 gpm

Positive Displacement Pumps

Maximum design pressure = 2,000 psig

Which one of the following pump configurations will supply the highest makeup flow rate to the system if system pressure is 500 psig?

- A. Two CPs in series
- B. Two CPs in parallel
- C. Two PDPs in parallel
- D. One CP and one PDP in series (CP supplying PDP)



TOPIC: 193006
KNOWLEDGE: K1.15 [3.1/3.3]
QID: P2481 (B2479)

Water at 90°F and 50 psig is flowing through a 10-inch diameter pipe at 100 lbm/sec. The pipe then splits into two pipes, a 3-inch diameter pipe and a 6-inch diameter pipe.

Disregarding any flow restrictions other than pipe size, which one of the following lists the approximate flow rates through the 3-inch and 6-inch diameter pipes. (Assume that water velocity is the same in each pipe.)

	3-inch Pipe <u>(lbm/sec)</u>	6-inch Pipe <u>(lbm/sec)</u>
A.	10	90
B.	20	80
C.	25	75
D.	33	67



TOPIC: 193006
KNOWLEDGE: K1.15 [3.1/3.3]
QID: P2582 (B2581)

Water at 90°F and 50 psig is flowing through a 10-inch diameter pipe at 100 lbm/sec. The pipe then splits into two pipes, a 6-inch diameter pipe and an 8-inch diameter pipe.

Disregarding any flow restrictions other than pipe size, which one of the following lists the approximate flow rates through the 6-inch and 8-inch diameter pipes? (Assume that water velocity is the same in each pipe.)

	6-inch Pipe <u>(lbm/sec)</u>	8-inch Pipe <u>(lbm/sec)</u>
A.	24	76
B.	32	68
C.	36	64
D.	40	60



TOPIC: 193006
KNOWLEDGE: K1.15 [3.1/3.3]
QID: P2783 (B2723)

Two identical centrifugal pumps (CPs) and two identical positive displacement pumps (PDPs) are able to take suction on a vented water storage tank and provide makeup water flow to a cooling water system. The pumps are capable of being cross-connected to provide multiple configurations. In single pump alignment, each pump will supply 100 gpm at a system pressure of 1,200 psig.

Given the following information:

Centrifugal Pumps

Shutoff head = 1,500 psig
Maximum design pressure = 2,000 psig
Flow rate with no backpressure = 180 gpm

Positive Displacement Pumps

Maximum design pressure = 2,000 psig

Which one of the following pump configurations will supply the highest makeup flow rate to the cooling water system if system pressure is 1,700 psig?

- A. Two CPs in series
- B. Two CPs in parallel
- C. Two PDPs in parallel
- D. One CP and one PDP in series (CP supplying PDP)



TOPIC: 193006
KNOWLEDGE: K1.15 [3.1/3.3]
QID: P3183

A four-loop PWR nuclear power plant uses four identical reactor coolant pumps (RCPs) to supply reactor coolant flow through the reactor vessel. The plant is currently operating at 20 percent power with all RCPs in operation.

Which one of the following describes the stable RCS flow rate through the reactor vessel following the trip of one RCP? (Assume that no operator actions are taken and the reactor does not trip.)

- A. Less than 75 percent of the original flow rate.
- B. Exactly 75 percent of the original flow rate.
- C. Greater than 75 percent of the original flow rate.
- D. Unpredictable without pump curves for the RCPs.



TOPIC: 193006
KNOWLEDGE: K1.15 [3.1/3.3]
QID: P3582

A reactor shutdown has been performed because of leakage from the reactor coolant system (RCS) to a steam generator (SG) via a tube leak.

Given the following current conditions:

- SG pressure is 1,000 psia.
- RCS pressure is 2,200 psia.
- RCS average temperature is 500°F.
- Leak rate from the RCS to the SG is 100 gpm.

If RCS pressure is decreased to 1,600 psia, with no other changes in plant parameters, what will be the approximate leak rate from the RCS to the SG?

- A. 50 gpm
- B. 71 gpm
- C. 79 gpm
- D. 85 gpm



TOPIC: 193006
KNOWLEDGE: K1.15 [3.1/3.3]
QID: P3683 (B3681)

Two identical single-speed centrifugal pumps (CPs) and two identical single-speed positive displacement pumps (PDPs) are able to take suction on a vented water storage tank and provide makeup water flow to a cooling water system. The pumps are capable of being cross-connected to provide multiple configurations. In single pump alignment, each pump will supply 100 gpm at a system pressure of 1,200 psig.

Given the following information:

Centrifugal Pumps

Discharge pressure at shutoff head = 1,500 psig
Maximum design pressure = 2,000 psig
Flow rate with no backpressure = 180 gpm

Positive Displacement Pumps

Maximum design pressure = 2,000 psig

Which one of the following pump configurations will supply the highest initial flow rate to a cooling water system that is drained and depressurized?

- A. Two CPs in series
- B. Two CPs in parallel
- C. Two PDPs in parallel
- D. One CP and one PDP in series (CP supplying PDP)



TOPIC: 193006
KNOWLEDGE: K1.15 [3.1/3.3]
QID: P4243 (B4242)

Refer to the drawing of a venturi in a main steam line (see figure below). The venturi inlet and outlet pipe diameters are equal.

A main steam line break downstream of the venturi causes the main steam mass flow rate through the venturi to increase. Soon, the steam reaches sonic velocity in the throat of the venturi.

How will the main steam mass flow rate through the venturi be affected as the steam pressure downstream of the venturi continues to decrease?

- A. It will continue to increase at a rate that is dependent on the steam velocity in the throat of the venturi.
- B. It will continue to increase at a rate that is dependent on the differential pressure ($P_1 - P_2$) across the venturi.
- C. It will not continue to increase because the steam velocity cannot increase above sonic velocity in the throat of the venturi.
- D. It will not continue to increase because the differential pressure ($P_1 - P_2$) across the venturi cannot increase further once the steam reaches sonic velocity in the throat of the venturi.

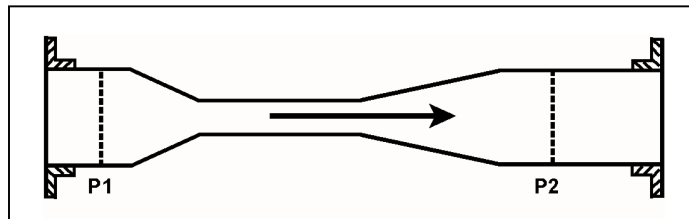

TOPIC: 193006
KNOWLEDGE: K1.15 [3.1/3.3]
QID: P4343 (B4342)

Two identical single-speed centrifugal pumps (CPs) and two identical single-speed positive displacement pumps (PDPs) are able to take suction on a vented water storage tank and provide makeup water flow to a cooling water system. The pumps are capable of being cross-connected to provide multiple configurations. In single pump alignment, each pump will supply 100 gpm at a system pressure of 1,200 psig.

Given the following information:

Centrifugal Pumps

Discharge pressure at shutoff head = 1,500 psig
Maximum design pressure = 2,000 psig
Flow rate with no backpressure = 180 gpm

Positive Displacement Pumps

Maximum design pressure = 2,000 psig

Which one of the following pump configurations will supply the lowest initial flow rate of makeup water to a cooling water system that is drained and depressurized?

- A. Two CPs in series
- B. Two CPs in parallel
- C. Two PDPs in parallel
- D. One CP and one PDP in series (CP supplying PDP)



TOPIC: 193006
KNOWLEDGE: K1.15 [3.1/3.3]
QID: P4543 (B4542)

Refer to the drawing of a main water header that splits into two parallel headers (see figure below).

Header A has a 2-inch diameter and header B has a 3-inch diameter. The velocity of the water in both headers is the same.

If the main water header has a flow rate of 500 gpm, what is the approximate flow rate in each of the parallel headers?

	Header A (gpm)	Header B (gpm)
A.	125	375
B.	154	346
C.	200	300
D.	222	278

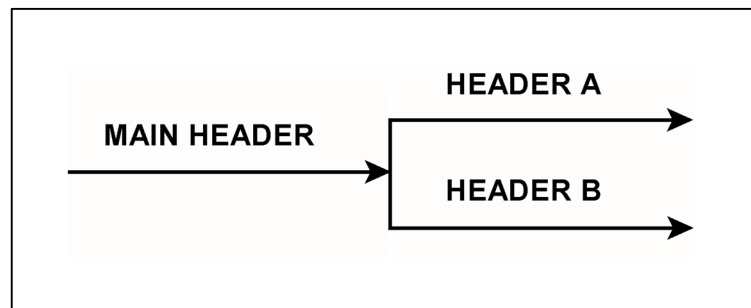

TOPIC: 193006
KNOWLEDGE: K1.15 [3.1/3.3]
QID: P4643 (B4642)

A length of pipe in a cooling water system uses a reducer fitting to decrease the pipe diameter from 6 inches to 4 inches. The flow rate in the 6-inch diameter section of pipe is 200 gpm. What is the flow rate in the 4-inch diameter section of pipe?

- A. 133 gpm
- B. 200 gpm
- C. 300 gpm
- D. 450 gpm



TOPIC: 193006
KNOWLEDGE: K1.15 [3.1/3.3]
QID: P4743

A four-loop PWR nuclear power plant uses four identical single-speed reactor coolant pumps (RCPs) to supply reactor coolant flow through the reactor vessel. The plant is currently shut down with one RCP in operation.

Which one of the following describes the stable reactor coolant flow rate through the reactor vessel following the start of a second RCP?

- A. Less than twice the original flow rate.
- B. Exactly twice the original flow rate.
- C. More than twice the original flow rate.
- D. Cannot be determined without additional information.



TOPIC: 193006
KNOWLEDGE: K1.15 [3.1/3.3]
QID: P5543 (B5542)

A vented water storage tank contains 60 feet of water at 70°F. A cracked weld at the bottom of the tank results in a leak rate of 12 gpm. If makeup water flow rate is 5 gpm, at what water level will the tank stabilize?

- A. 38.7 feet
- B. 25.0 feet
- C. 10.4 feet
- D. 0.0 feet



TOPIC: 193006
KNOWLEDGE: K1.15 [3.1/3.3]
QID: P5943 (B5942)

A vented water storage tank contains 64 feet of water at 70°F. A cracked weld at the bottom of the tank results in a leak rate of 12 gpm. At what water level will the leak rate be 3 gpm?

- A. 48 feet
- B. 32 feet
- C. 16 feet
- D. 4 feet



TOPIC: 193006
KNOWLEDGE: K1.15 [3.1/3.3]
QID: P6143 (B6142)

A plant shutdown will be performed because of leakage from the main condenser cooling water system into the main condenser via a tube leak.

Given the following initial conditions:

- Main condenser pressure is 1.7 psia.
- Atmospheric pressure is 14.7 psia
- Main condenser cooling water pressure at the location of the tube leak is 18 psig.
- Cooling water leak rate into the main condenser is 80 gpm.

If the main condenser is brought to atmospheric pressure, with no changes to the main condenser cooling water system parameters, what will be the approximate rate of cooling water leakage into the main condenser?

- A. 36 gpm
- B. 52 gpm
- C. 61 gpm
- D. 72 gpm



TOPIC: 193006
KNOWLEDGE: K1.15 [3.1/3.3]
QID: P6543 (B6542)

An ideal positive displacement pump is operating in an open system with the following initial parameters:

Suction pressure = 10 psig
Discharge pressure = 25 psig
Flow rate = 100 gpm

If the pump discharge pressure increases to 40 psig, the pump flow rate will...

- A. remain constant.
- B. decrease in direct proportion to the change in pump differential pressure.
- C. decrease in direct proportion to the square of the change in pump differential pressure.
- D. decrease in direct proportion to the square root of the change in pump differential pressure.



TOPIC: 193006
KNOWLEDGE: K1.15 [3.1/3.3]
QID: P6743 (B6742)

A centrifugal pump is operating at a constant speed in a closed system with the following initial parameters:

Suction pressure = 10 psig
Discharge pressure = 25 psig
Pump flow rate = 500 gpm

If the pump discharge flow control valve is throttled such that the pump discharge pressure increases to 40 psig, the change in pump flow rate will be...

- A. directly proportional to the square of the change in pump differential pressure.
- B. directly proportional to the square root of the change in pump differential pressure.
- C. inversely proportional to the square root of the change in pump differential pressure.
- D. impossible to determine from the provided information.



TOPIC: 193006
KNOWLEDGE: K1.15 [3.1/3.3]
QID: P6843 (B6842)

Refer to the drawing of a venturi in a steam line (see figure below). The venturi inlet and outlet pipe diameters at P1 and P2 are equal.

Currently, steam is flowing through the venturi, reaching sonic velocity in the throat of the venturi. If the steam inlet pressure (P1) remains constant while the downstream pressure (P2) decreases, the mass flow rate of the steam will _____; and the velocity of the steam at the venturi outlet will _____.

- A. increase; increase
- B. increase; remain the same
- C. remain the same; increase
- D. remain the same; remain the same

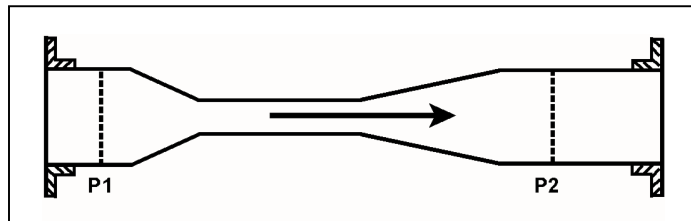

TOPIC: 193006
KNOWLEDGE: K1.15 [3.1/3.3]
QID: P7143

The following are current parameter values for an operating PWR nuclear power plant:

Steam generator (SG) pressure = 1,000 psia
Main feed pump (MFP) discharge pressure = 1,220 psia

If SG pressure does not change, what MFP discharge pressure will increase main feedwater mass flow rate by 10 percent? (Assume MFP inlet temperature remains the same. Also, assume all valves/components that contribute to head loss downstream of the MFP remain in their current configuration.)

- A. 1,242 psia
- B. 1,266 psia
- C. 1,293 psia
- D. 1,342 psia



TOPIC: 193006
KNOWLEDGE: K1.15 [3.1/3.3]
QID: P7543 (B7542)

Which one of the following will increase the head loss occurring in an operating cooling water system?

- A. Shifting two heat exchangers from parallel to series operation.
- B. Increasing the flow rate in the system by throttling open a flow control valve.
- C. Replacing a 20 foot section of 10-inch diameter pipe with a 10 foot section of 10-inch diameter pipe.
- D. Replacing a 20 foot section of 10-inch diameter pipe with a 20 foot section of 12-inch diameter pipe.



TOPIC: 193006
KNOWLEDGE: K1.15 [3.1/3.3]
QID: P7660 (B7660)

Which one of the following will decrease the head loss occurring in an operating cooling water system?

- A. Shifting two heat exchangers from parallel to series operation.
- B. Increasing the flow rate in the system by positioning a flow control valve more open.
- C. Replacing a 10 foot length of 10-inch diameter pipe with a 20 foot length of 10-inch diameter pipe.
- D. Replacing a 20 foot length of 12-inch diameter pipe with a 20 foot length of 10-inch diameter pipe.



TOPIC: 193006
KNOWLEDGE: K1.15 [3.1/3.3]
QID: P7669 (B7669)

Refer to the drawing of a main water header that splits into two parallel headers (see figure below).

Header A has a 2-inch diameter and header B has a 4-inch diameter. The velocity of the water in both headers is the same.

If the main water header has a flow rate of 500 gpm, what is the approximate flow rate in each of the parallel headers?

	Header A (gpm)	Header B (gpm)
A.	100	400
B.	125	375
C.	167	333
D.	200	300

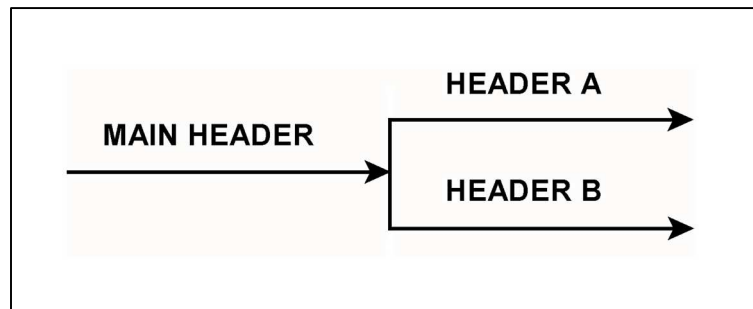

TOPIC: 193006
KNOWLEDGE: K1.15 [3.1/3.3]
QID: P7710 (B7710)

A vented water storage tank contains 30 feet of water at 70°F. A cracked weld at the bottom of the tank causes an initial leak rate of 12 gpm. If makeup water flow rate is 8 gpm, at what water level will the tank stabilize?

- A. 24.5 feet
- B. 20.0 feet
- C. 13.3 feet
- D. 0.0 feet

